



deploy

IPv6 and xDSL

Speaker name
email address



Copy ... Rights

- This slide set is the ownership of the 6DEPLOY project via its partners
- The Powerpoint version of this material may be reused and modified only with written authorization
- Using part of this material must mention 6DEPLOY courtesy
- PDF files are available from www.6deploy.org
- Looking for a contact ?
 - Mail to : martin.potts@martel-consulting.ch

Outline

- Entities in an xDSL Environment
- Ethernet Bridging over ATM
- PPP over AAL5 (PPPoA) – PTA
- PPP over AAL5 (PPPoA) – LAA
- PPP over Ethernet (PPPoE)
- IPv6 and Radius
- IPv6 and Radius Attributes

Entities in an xDSL Environment

- Subscriber (xDSL User)
 - PCs, modem, bridge/router
- Network Access Provider (NAP)
 - Responsible for the management of the copper local loop.
 - DSLAM, BBRAS, radius server*

Entities in an xDSL Environment (#2)

- Network Service Provider
 - Responsible for providing interconnection with the Internet. May offer other added-value services.
 - Edge router, radius server

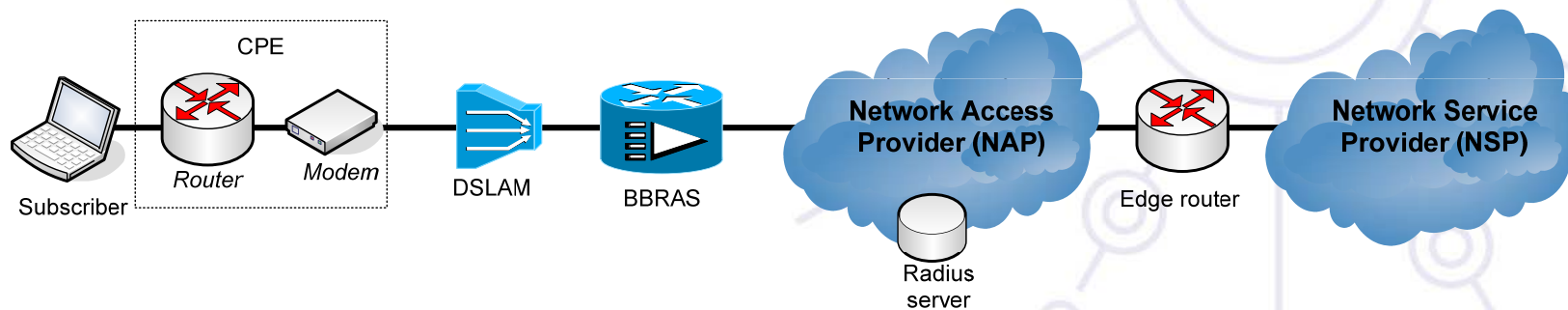

Implementation Details

- xDSL modem
 - Encapsulates Subscribers' traffic to ATM cells, signal (de)modulation
- DSL Access Multiplexer (DSLAM)
 - Signal (de)modulation, aggregates traffic over ATM links
- Broad Band Remote Access Concentrator (BBRAS)
 - Terminates the Subscribers' ATM connections, tunnels or routes traffic to the *NSP* edge router.

Implementation Details

- Radius Server
 - Contains subscriber configuration templates
- NSP edge router
 - Terminates PPP sessions or L2TP tunnels, gateway to Internet

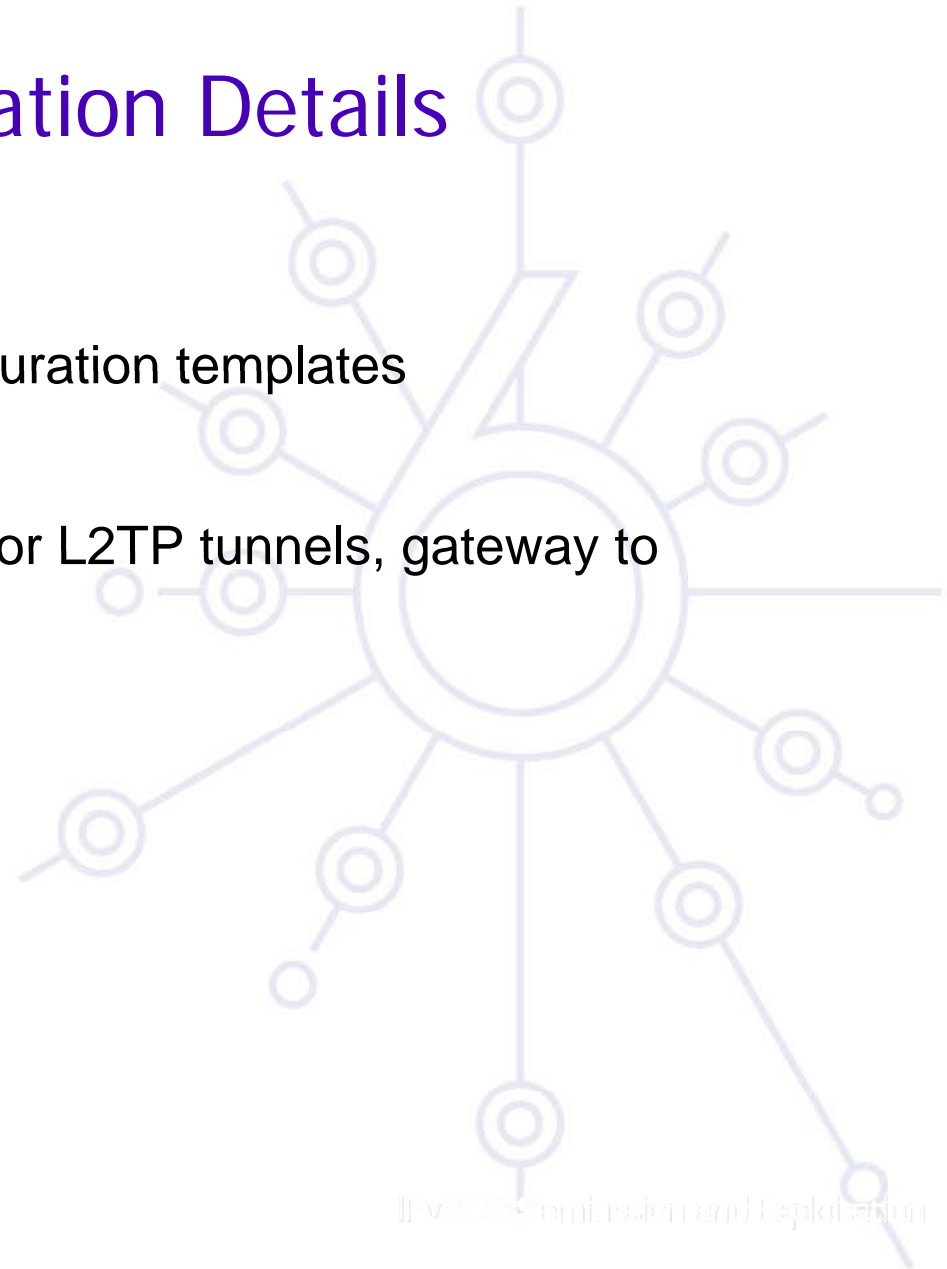

Ethernet Bridging over ATM

- The CPE forwards IP packets using multi-protocol encapsulation over ATM adaptation layer 5 (AAL5).
- Minimum functionality is required for CPE, aka xDSL modem (L3 unaware device).
- A single ATM PVC is used for IPv4/6 interconnection
- Subscriber's PCs are configured with static IPv6 address, or via DHCPv6 or via auto-configuration
- This method does not support authentication and authorization functionality!

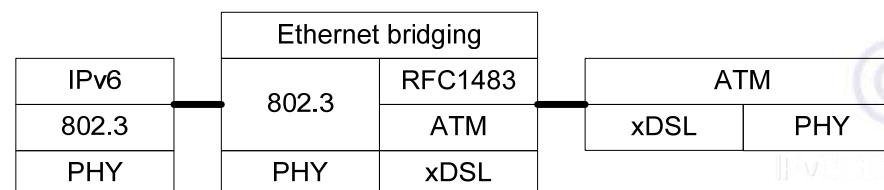
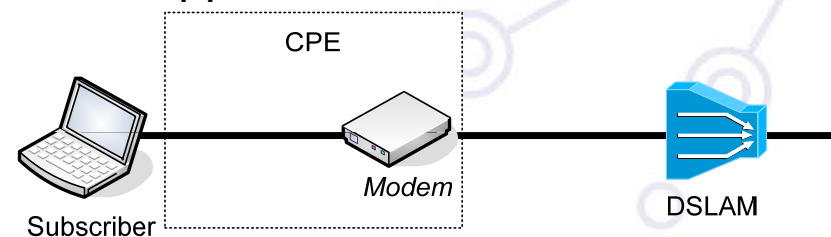

PPP over AAL5 (PPPoA) - PTA

- The CPE supports IPv6/4 packet forwarding and interconnects multiple systems in the *Subscriber's* local network.
- A single PPPoA session is established over a ATM PVC allowing the CPE router to establish two PPP sessions; an IPv6 (IPCPv6) and an IPv4 (IPCPv4).
- IPv6 addresses are assigned automatically over the PPP session using attributes stored in a centralised radius server or local database.
- The CPE can be authenticated using one of the multiple protocols, such as PAP, CHAP, MS-CHAP, EAP, etc.

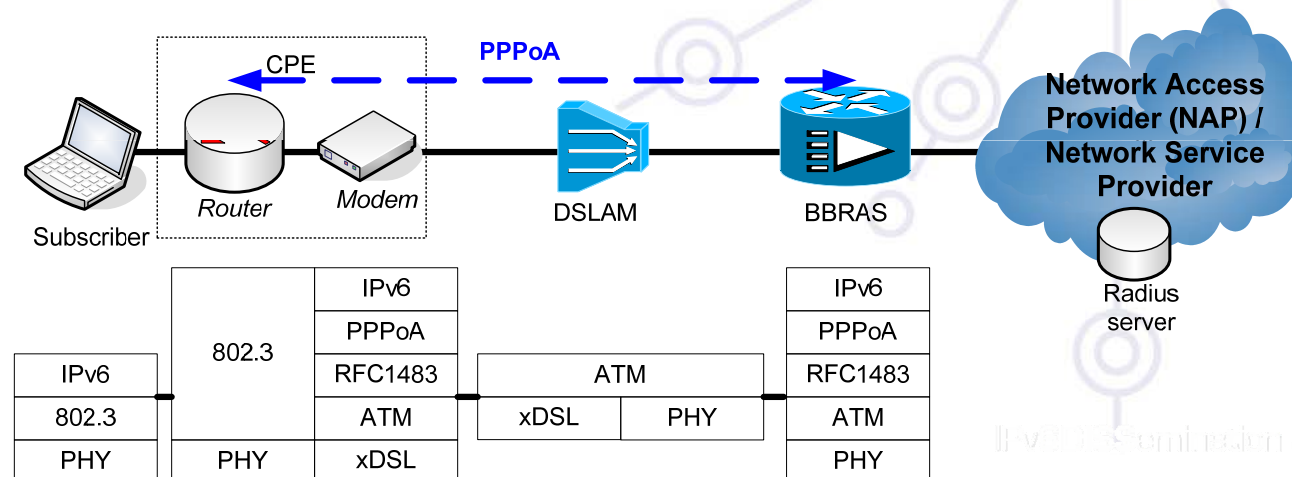

PPP over AAL5 (PPPoA) - LAA

- In case the *NAP* and the *NSP* are different, the PPP sessions do not terminate at the *BBRAS* but at the edge router.
 - BBRAS = *L2TP Access Concentrator (LAC)*
 - Edge router = *L2TP Network Server (LNS)*
- Two PPP sessions are established from the CPE router, which terminate at the *LNS*. *LAC* is IPv6-unaware.
- Address assignment and authentications methods are performed in the same way as previously but now the radius server is managed by the *NSP*.

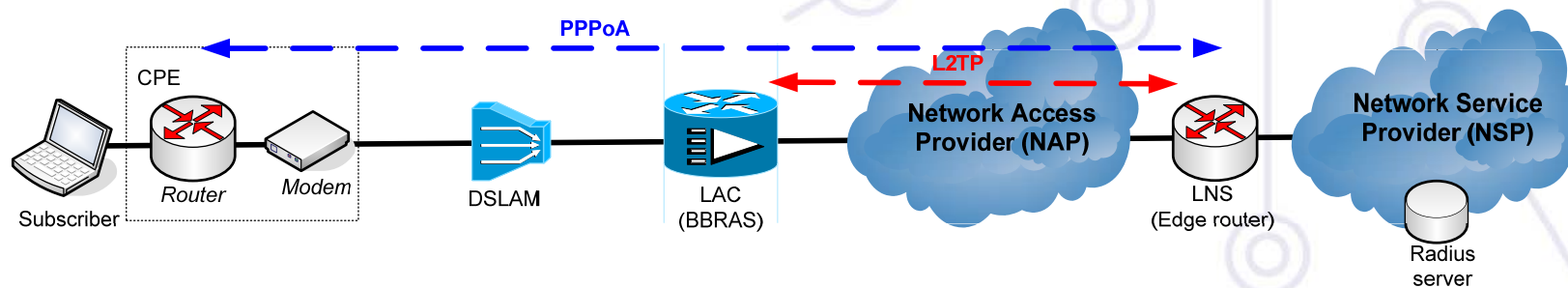

PPP over Ethernet (PPPoE)

- Separate PPP sessions are established between the Subscriber's systems (or CPE) and the BBRAS for IPv6 and IPv4 traffic.
 - Same IPv4/6 address allocation schema as in PPPoA
 - Sessions may terminate in the LNS in the NSP network (not shown).
 - If PPP sessions terminate at the *Subscriber's* system, then the CPE may be L3 unaware, aka cheap(!). It requires, however, specific software to be installed in the *Subscribers'* systems. The advantage of this approach is that allows access control and service selection to be done on per-subscriber rather than on per-site basis.

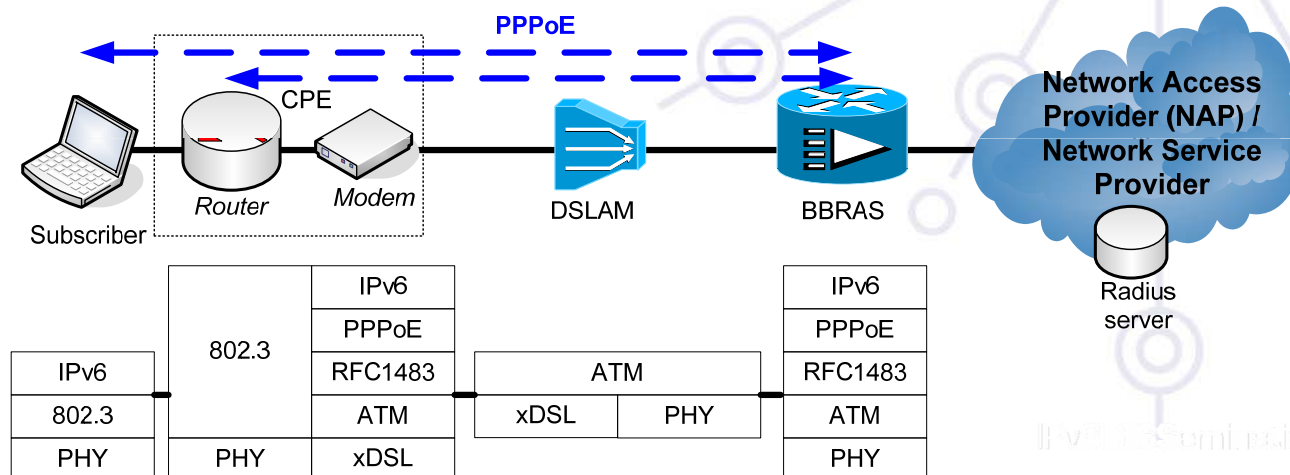

IPv6 and Radius

- Radius protocol
 - Provides authentication, authorisation and accounting services
 - Necessary in any xDSL deployments, e.g. stores large number of user information instead of keeping them in the LNS
 - Provides configuration data, e.g. IPv4/v6 address allocation, ACLs

IPv6 and Radius

- Radius message exchange
 - The IPv6 attributes may be sent along with IPv4-related attributes within the same RADIUS message and that the NAS will decide which attributes to use
 - A NAS sending a RADIUS *Access-Request* may not know a-priori whether the host will be using IPv4, IPv6, or both. For example, within PPP, IPv6CP occurs after LCP, so that address assignment will not occur until after RADIUS authentication and authorization has completed.

IPv6 and Radius Attributes (RFC3162)

- **NAS-IPv6-Address:** Indicates the identifying IPv6 Address of the NAS which is requesting authentication of the user. NASIPv6-Address is only used in *Access-Request* packets
- **Framed-Interface-Id:** Specifies the IPv6 interface ID to be assigned to a user
- **Framed-IPv6-Prefix:** Specifies the IPv6 networks to be assigned to a user.

IPv6 and Radius Attributes (RFC3162) #2

- **Framed-IPv6-Route:** Specifies the IPv6 routing information to be configured for the user on the RAS.
- **Framed-IPv6-Pool:** Specifies the name of a RAS managed pool from which the RAS should assign an IPv6 prefix
- **Login-IPv6-Host:** Indicates the system with which to connect the user, when the Login-Service Attribute is included.

IPv6 configuration in End User

- **Microsoft**
 - Windows XP or earlier version: PPPv6 not supported
 - Windows Vista: Embedded support, without user configuration
- **MacOS**
- **Linux, FreeBSD**
 - *pppd*, *dhcpc6* (WIDE Kame project), *rtadvd*